

Code No: 152AH

JAWAHARLAL NEHRU TECHNOLOGICAL UNIVERSITY HYDERABAD

B. Tech I Year II Semester Examinations, January/February - 2024

ENGINEERING MECHANICS

(Common to CE, ME, MCT, MMT, AE, MIE)

Time: 3 Hours

Max. Marks: 75

Note: i) Question paper consists of Part A, Part B.

ii) Part A is compulsory, which carries 25 marks. In Part A, answer all questions.

iii) In Part B, Answer any one question from each unit. Each question carries 10 marks and may have a, b as sub questions.

PART - A**(25 Marks)**

- 1.a) Define the term free body diagram. [2]
- b) A force $F = (10 \mathbf{i} + 8 \mathbf{j} - 5 \mathbf{k})$ N acts at point A (2, 5, 6) m. What is the moment of the force about the point B (3, 1, 4). [3]
- c) Define angle of friction and angle of repose. [2]
- d) The force required to pull a body of weight 100 N on a rough horizontal plane is 30 N. Determine the coefficient friction if the force applied is at an angle of 15° with the horizontal. [3]
- e) Find the centroidal coordinates of rectangular area of width w and depth d . [2]
- f) Determine the moment of inertia of an area of semi-circle of radius 2.5 cm about the centroidal x and y axes. [3]
- g) State parallel axis theorem as applied to mass moment of inertia. [2]
- h) Mention the forces which are generally omitted while applying the principle of virtual work. [3]
- i) Write the impulse-momentum equation and mention its application. [2]
- j) Show that when a particle moves with simple harmonic motion, its time for complete oscillation is independent of the amplitude of its motion. [3]

PART - B**(50 Marks)**

- 2.a) A bracket is constructed by attaching member ABC to wall CD with a frictionless hinge at C and a horizontal cable at A, as shown in Figure 1. A smooth cylinder of weight 1.2 kN is placed in the bracket as shown. Determine the force acting on the cylinder at contact points B and D and the tension in the cable and reactions at support C.

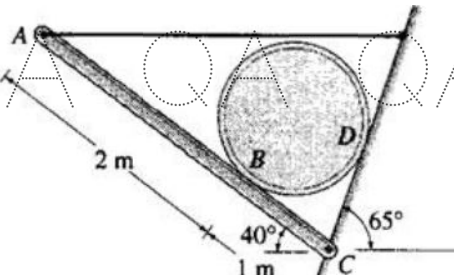

Figure 1

QA QA QA QA QA QA QA QA QA

- b) Refer to figure 2. If the maximum allowable strength for each cable is 10.5 kN, determine the permissible weight of the homogeneous circular plate of diameter 4m. [5+5]

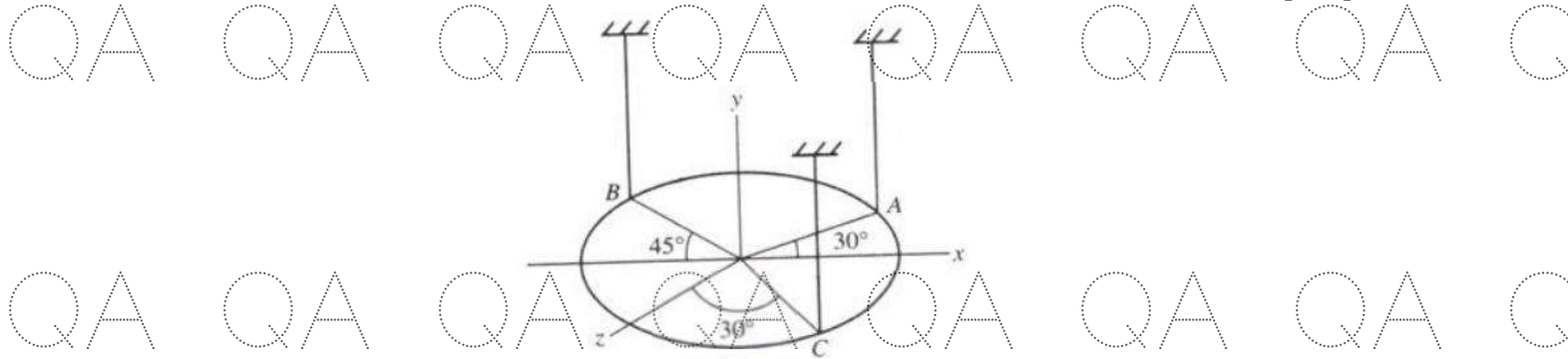

Figure: 2

OR

- 3.a) Find the reactions at supports A and B for the force system acting on the beam as shown in Figure 3.

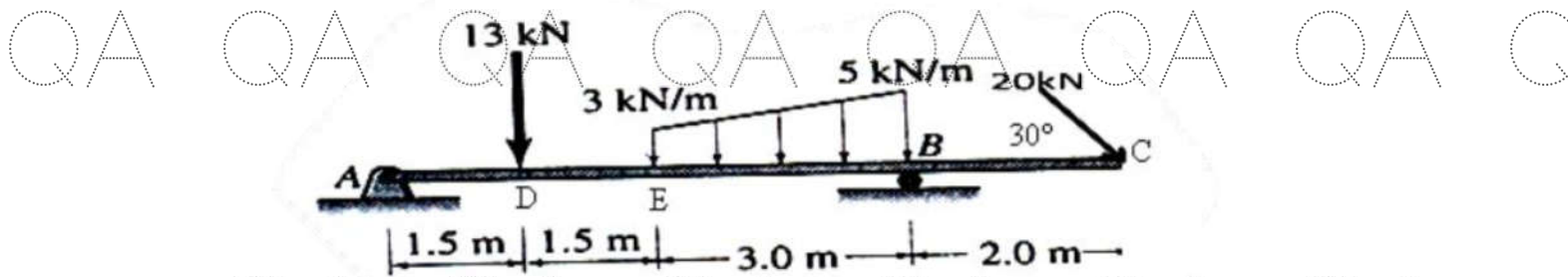

Figure: 3

- b) A crate of weight $W = 1.5 \text{ kN}$ is supported as shown in figure 4, by members AO and AB and cable AC. Determine the force in the cable AC and in members AO and AB. [5+5]

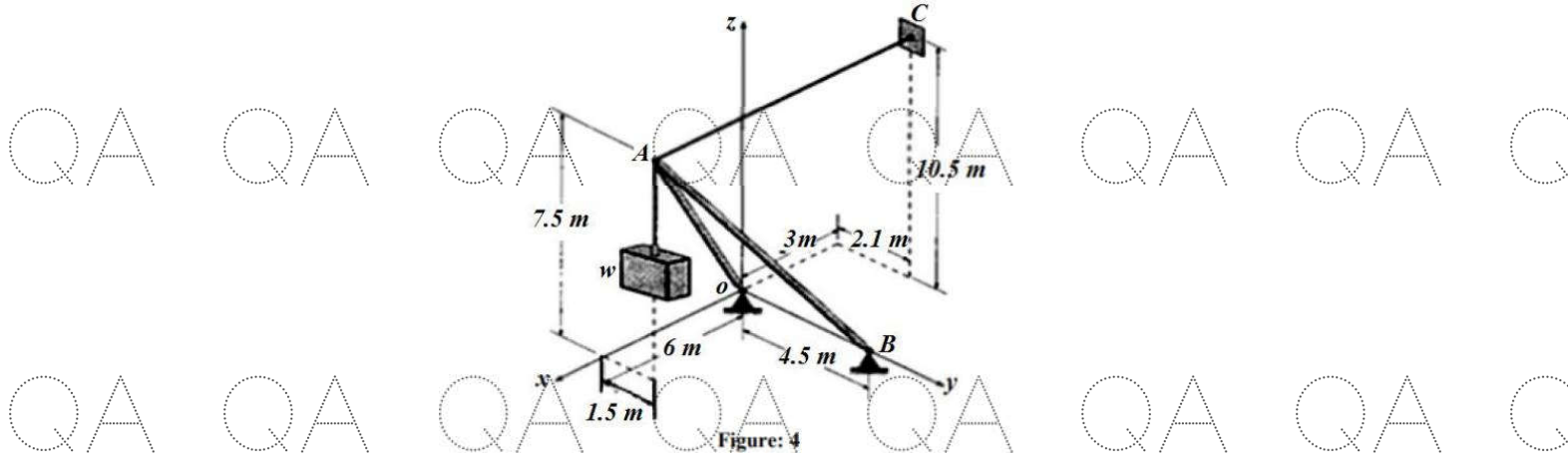

Figure: 4

QA QA QA QA QA QA QA QA QA

QA QA QA QA QA QA QA QA QA

- 4.a) As shown in figure 5, two blocks each weighing 20 kN and resting on a horizontal surface, are to be pushed apart by a 300 wedge. The angle of friction is 15° for all contact surfaces. What value of P is required to start movement of the blocks?

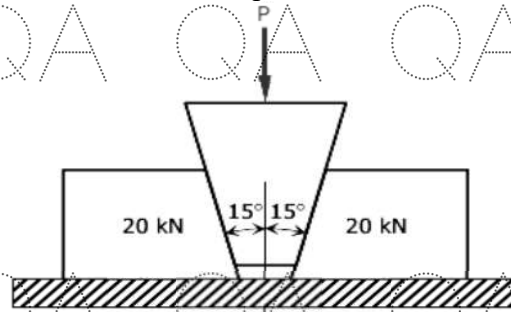

Figure: 5

- b) A screw jack has square threads of mean diameter 6 cm, of helix angle 10° and coefficient of friction 0.25. Determine the force that must be applied to the end of 50 cm lever to i) rise ii) lower a weight of 2500 N. [5+5]

OR

- 5.a) A ladder 5 m long rests on a horizontal ground and leans against a smooth vertical wall at an angle of 70° with the horizontal. The weight of the ladder is 300 N. The ladder is on the verge of sliding when a man weighing 750 N stands on a rung 1.5 m along the ladder. Calculate the coefficient of friction between the ladder and the floor.

- b) What should be the value of θ in figure 6 which will make the motion of 900 N block down the plane to impend? The coefficient of friction for all contact surfaces is 0.3. [5+5]

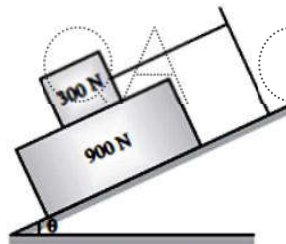

Figure: 6

- 6.a) For the shaded area as shown in figure 7, determine the Moment of Inertia of an area of plane figure about their centroidal axes. All units are in centimeters.

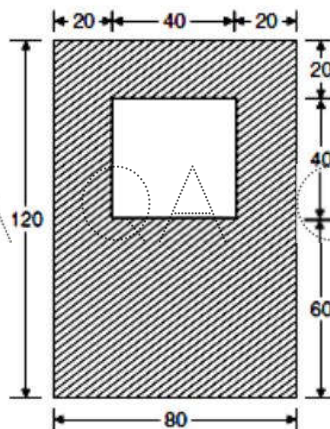

Figure 7

QA QA QA QA QA QA QA QA QA

QA QA QA QA QA QA QA QA QA

- b) Find the centroidal coordinates of the area of the plane as shown in figure 8 given $a = 30$ cm, $b = 30$ cm, $c = 60$ cm, $d = 40$ cm, and $r = 20$ cm. [5+5]

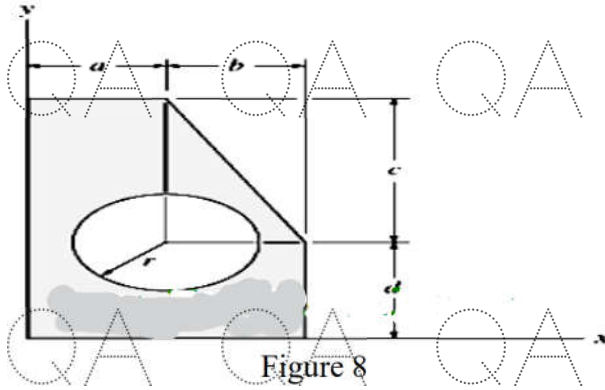

Figure 8
OR

- 7.a) Determine the centroidal coordinates of shade area with respect to x and y axes as shown in figure 9.

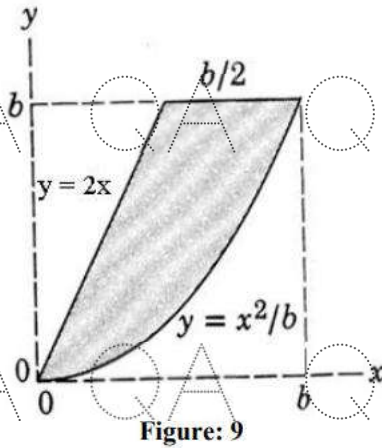

Figure: 9

- b) Determine the moment of inertia an area of a triangle with a rectangular cut as shown in figure 10, about the base A-B and the centroidal axis parallel to AB. (All dimensions are in Centimetres). [5+5]

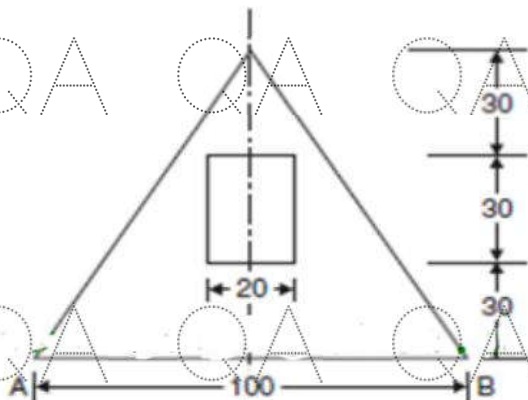

Figure: 10

QA QA QA QA QA QA QA QA QA

- 8.a) Find the mass moment of inertia of a solid sphere of radius r and mass m about any axis.
- b) The arrangement as shown in figure 11 is required to remain in state of equilibrium. Derive an expression for tension in the cable in terms of θ and W . Use method of virtual work. [5+5]

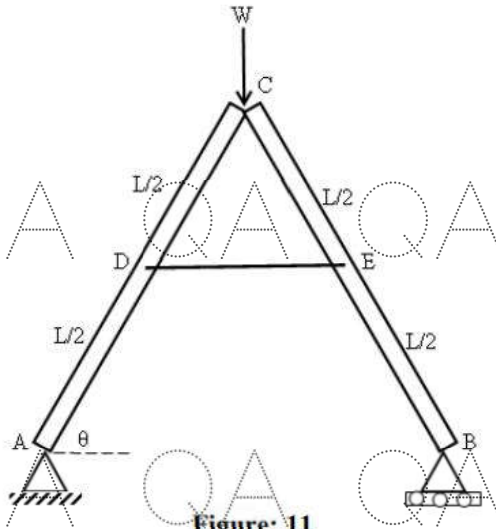

Figure: 11

OR

- 9.a) Find the mass moment of inertia of a solid cylinder of radius r , height h and mass m about centroidal x and y axes.
- b) A uniform ladder of 200 N weights rests against a smooth vertical wall and a rough horizontal floor making an angle of 60° with the horizontal. Use the method of virtual work, find the frictional force between the foot of the ladder and the rough horizontal floor. [5+5]
- 10.a) An elevator gross weight 15 kN is moving in the upward direction, such that the displacement is given by $x = t^3 - 4t^2 + 6t + 7$ m. Determine the tension in the cable supporting the elevator at $t = 2$ seconds.
- b) A car starts from rest on a curved road of 250 m radius and accelerates at a constant tangential acceleration of 0.6 m/sec^2 . Determine the distance and time for which that car travel before the magnitude of total acceleration attained it becomes 0.75 m/sec^2 . [5+5]

OR

- 11.a) A body of mass 10 kg is suspended by a string of length 1m. It is struck by a bullet travelling horizontally with a velocity of 450 m/sec. The bullet weights 30 grams and gets embedded into the body after striking it. Determine the maximum angle through which the body swings
- b) A body moving with simple harmonic motion has amplitude of 1 m and a period of oscillation of 2 seconds. What will be its velocity and acceleration 0.4 seconds after passing an extreme position? [5+5]

---ooOoo---